

The Charge and Nature of the α -Particle.

By Professor E. RUTHERFORD, F.R.S., and HANS GEIGER, Ph.D., John Harling
Fellow, University of Manchester.

(Read June 18 ; MS. received July 17, 1908.)

In the previous paper, we have determined the number of α -particles expelled per second per gramme of radium by a direct counting method. Knowing this number, the charge carried by each particle can be determined by measuring the total charge carried by the α -particles expelled per second from a known quantity of radium. Since radium C was used as a source of radiation in the counting experiments, it was thought desirable to determine directly the charge carried by the α -particles expelled from this substance. In a paper some years ago,* one of us has investigated the experimental conditions necessary for an accurate determination of the total charge carried by the α -rays, and has measured the charge carried by the α -particles expelled from a thin film of radium itself. In the present experiments the same general method has been used, with certain modifications, rendered necessary by the choice of radium C as a source of α -rays.

The experimental arrangement is clearly seen in fig. 1. A cylindrical glass tube HH of diameter 4 cm. is closed at the ends by ground-glass stoppers D, E. The source of radiation R is attached to the lower stopper E. The radiation from this passes into the testing chamber, which is rigidly attached to the stopper D by means of an ebonite tube F. The testing chamber consists of two parallel plates A and B about 2 mm. apart. A circular opening, 1.92 cm. in diameter, cut in the brass plate B, is covered by a sheet of thin aluminium foil. The upper chamber AC consists of a shallow brass vessel of aperture 2.5 cm., the lower surface of which is covered also with a sheet of aluminium foil.† The plate B is connected through a side glass tube to one terminal of a battery, the other pole of which is earthed. The chamber AC, which is insulated from the plate B, is connected with one pair of quadrants of a Dolezalek electrometer, the other of which is earthed. The whole apparatus is placed between the poles NS of a large electromagnet marked by the dotted lines in the figure, so that the α -rays in their passage from the source R to the testing chamber pass through a strong magnetic field.

When the active matter was placed in position, the apparatus was

* Rutherford, 'Phil. Mag.', August, 1905.

† The stopping power of each aluminium foil corresponded to about 5 mm. of air.

The Charge and Nature of the α -Particle.

163

exhausted by means of a Fleuss pump. The evacuation was then completed by means of a tube of cocoanut charcoal immersed in liquid air. A very low vacuum is required in these experiments in order to reduce the ionisation of the residual gas by the α -rays to as low a value as possible. If this is not

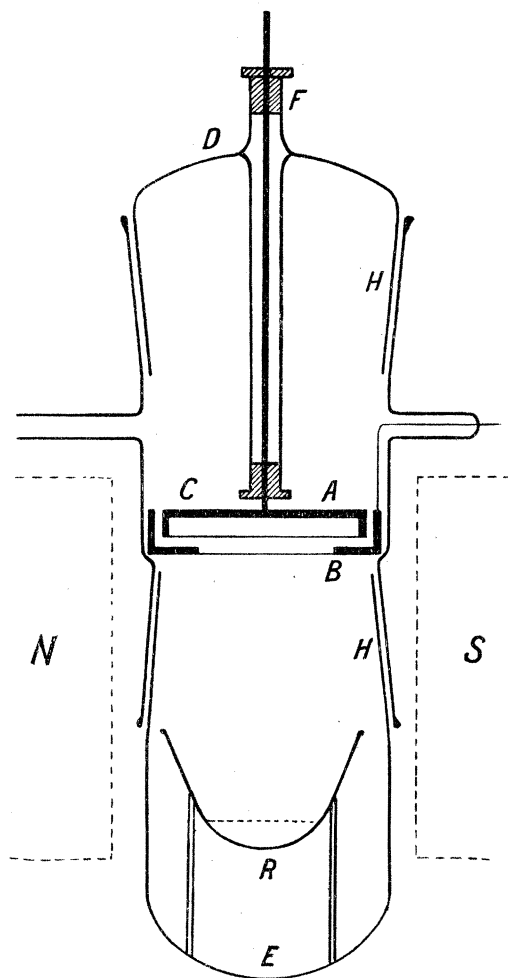

FIG. 1.

done, the positive charge communicated to the upper plate by the absorption of the α -particles may very rapidly leak away. In addition to the production of a high vacuum, it is necessary to place the testing chamber in a strong magnetic field. It is well known that the α -particles, in their passage through matter, liberate a large number of slow-velocity electrons, or δ -rays, as they have been termed by J. J. Thomson. The presence of a large number

of these negatively-charged particles impinging on the testing chamber completely masks the effect of the positive charge carried by the α -particles. By placing the testing chamber in a strong magnetic field, these slow-moving particles describe very small orbits, and return to the surface from which they were emitted. In this way the disturbing effect due to the δ -rays may be completely eliminated. On account of their very small velocity (about 10^8 cm.) and small mass, a magnetic field of only moderate intensity is required for the purpose. It will be observed that the α -particles are not fired directly into the upper plate AC, but pass first through a thin layer of aluminium foil. This arrangement was adopted in order to diminish as much as possible the number of δ -particles set free in the space between the electrodes. The α -rays pass readily through the thin layer of aluminium at the base of the vessel AC, and are completely stopped by the upper plate. The large number of δ -particles emitted from the plate AC by the impact of the α -rays cannot penetrate back through the aluminium foil, and consequently do not disturb the measurements. It is then only necessary, with the aid of the magnetic field, to get rid of the disturbance due to the δ -rays emitted from the two layers of aluminium foil.

In the present experiments the magnetic field served also for another purpose. Radium C emits β - as well as α -rays, and, in the absence of a magnetic field, these also would be partly absorbed, and give up their negative charges to the upper plate. In the experimental arrangement the magnetic field extended from the source R beyond the testing chamber. The source of radiation was placed about 3.5 cm. below the testing chamber. The strength of the magnetic field was then adjusted, so the β -particles were bent completely away from the lower plate and consequently did not produce any effect in the testing chamber. It was essential for this purpose that the source of radiation was some distance below the plate B, so that the strength of magnetic field obtainable under the experimental conditions and the length of path of the rays were together sufficient to ensure the complete deflection of the β -particles to one side of the glass tube before reaching the plate B.

As the source of radiation was some distance below the testing chamber, it was necessary to use a very active surface of radium C, in order to obtain a reasonably large effect for measurement. For this purpose a small shallow glass cap, represented by the source R in the figure, was attached by a ground-glass joint to a glass tube about 8 cm. long. This was filled with mercury, and the emanation from about 40 milligrammes of radium introduced by the aid of a mercury trough to the top of the cap. The level of the mercury below the top of the cap is represented by the dotted line in the figure. The

emanation was left in the cap for more than three hours, when the amount of radium C deposited on the interior walls of the glass cap and on the surface of the mercury reaches its maximum value. By means of the mercury trough, the emanation was then rapidly displaced, the mercury run out, and the cap removed from the glass tube. The inner surface of the cap was washed first with water and then with alcohol, to remove any trace of grease on the inside of the glass. The inner surface of the cap then acted as a source of intense α -radiation. Fifteen minutes after removal the α -radiation is homogeneous, and due entirely to radium C. The active glass cap was then placed in position in the testing vessel, which was then rapidly exhausted by a Fleuss pump. The cocoanut charcoal was then immersed in liquid air and a low vacuum reached in a short time. Usually an interval of 15 to 30 minutes after the removal of the emanation was required for the various operations and to obtain a sufficiently low vacuum for measurements to be started.

In order to determine the amount of radium C deposited in the glass cap, observations of its activity were made by the γ -rays *in situ*. For this purpose a γ -ray electroscope was placed some distance on one side of the apparatus, and the rate of discharge observed at intervals during the experiment. The electroscope was standardised in the usual way by means of the standard preparation of radium placed at the same distance as the source R from the electroscope, so that the amount of radium C distributed on the source at any time was determined in terms of the amount in equilibrium with a definite quantity of radium. Such measurements with the γ -rays can be very simply and accurately made, and, with suitable precautions, the error of observation should not be greater than 1 per cent.

Method of Calculation.

Using a strong magnetic field, the upper plate received a positive charge, whether the lower plate was charged positively or negatively. The current was first measured with the lower plate charged to a potential $+V$, and then with the same plate at a potential $-V$. Let i_1 be the current observed in the first case and i_2 in the second case; i_2 is always numerically less than i_1 , the ratio depending upon the degree of exhaustion. Let i_0 be the current through the gas due to the ionisation of the residual gas between the plates by the α -rays. Then

$$i_1 = i_0 + nE, \quad (1)$$

where n is the number of α -particles passing into the upper plate per second and E the charge on each. On reversing the voltage, the ionisation current is equal in magnitude but reversed in its direction.

166 Prof. E. Rutherford and Dr. H. Geiger. [July 17

Consequently $i_2 = nE - i_0$. (2)Adding (1) and (2), $nE = \frac{1}{2}(i_1 + i_2)$.

Let Q be the quantity of radium C present at any instant measured in terms of the γ -ray effect due to 1 gramme of radium, and N the number of α -particles of radium C expelled per second and per gramme of radium. The total number of α -particles expelled per second from the source R is QN . Let K be the fraction of the total number of α -particles expelled from the source which impinge on the upper plate. Then $n = KQN$, where K and Q are measured, and N is known from the counting experiments. Consequently the charge E on each α -particle is given by

$$E = (i_1 + i_2) / 2KQN.$$

In preliminary experiments, it was found that the values of i_1 and i_2 were independent of the voltage over the range examined, viz., from 2 to 8 volts. In most of the latter measurements an E.M.F. of ± 2 volts was used. It was found experimentally that the value of $\frac{1}{2}(i_1 + i_2)$ was independent of the strength of the magnetic field beyond a certain limit. For example, an increase of the current in the electromagnet from 10 to 20 amperes made no alteration in the magnitude of i_1 or i_2 . A current of 6 amperes gave distinctly smaller values, due to the fact that the strength of the field was not sufficient to bend away all the β -particles completely. In all the final experiments an exciting current of 12 amperes was used. The electromagnet and electrometer connections were well screened and the electrometer readings were remarkably steady. The external γ -ray effect due to the intense source of radiation was screened off as far as possible by plates of thick lead. The apparatus was placed some distance from the electrometer, the insulated connecting wire passing through a long brass tube connected with earth. Notwithstanding these precautions, it was impossible, in consequence of the ionisation due to the γ -rays, to avoid a small back leak of the electrometer system as its potential rose. This was easily corrected for in each observation by observing the rate of movement of the needle over each succeeding 10 divisions of the scale until a deflection of over 150 divisions was reached. The fraction K of the total number of α -particles striking the upper plate was determined on the assumption that the α -particles are emitted equally in all directions. The correctness of this assumption has been verified in other experiments. The distance of the radiant source from the lower plate was determined when in position by a cathetometer. The correction due to the fact that the radiation came from a source of sensible area was determined graphically by dividing up the surface into concentric rings and determining the value of K for each. In the experiments given

below the mean value of K was 0.0172. The value of N, as determined by the counting experiments, is 3.4×10^{10} . The following tables illustrate the results obtained in two distinct series of experiments:—

Experiment I.

I.	II.	III.	IV.	V.	VI.	VII.
No. of observations.	Intensity of radiation.	Capacity.	i_1 .	i_2 .	$\frac{1}{2}(i_1 + i_2)$.	E.
1	21.0 mg. Ra	495 cms.	2.24 divs./sec.	1.75 divs./sec.	1.99	8.8×10^{-10}
1	18.5 "	495 "	1.74 "	1.55 "	1.68	8.3×10^{-10}
2	13.9 "	495 "	1.61 "	1.27 "	1.44	9.2×10^{-10}
1	11.4 "	495 "	1.31 "	1.07 "	1.19	9.6×10^{-10}
1	10.6 "	495 "	1.19 "	0.92 "	1.05	9.1×10^{-10}
2	6.98 "	495 "	0.856 "	0.706 "	0.78	10.0×10^{-10}
2	3.08 "	146 "	1.11 "	0.87 "	0.99	8.7×10^{-10}
Mean value.....						9.2×10^{-10}

Experiment II.

I.	II.	III.	IV.	V.	VI.	VII.
No. of observations.	Intensity of radiation.	Capacity.	i_1 .	i_2 .	$\frac{1}{2}(i_1 + i_2)$.	E.
2	16.1 mg. Ra	495 cms.	1.90 divs./sec.	1.47 divs./sec.	1.68	9.3×10^{-10}
1	14.8 "	495 "	1.63 "	1.28 "	1.45	9.1×10^{-10}
2	10.7 "	304 "	2.06 "	1.84 "	1.95	10.0×10^{-10}
1	9.8 "	304 "	1.85 "	1.40 "	1.62	9.9×10^{-10}
2	6.32 "	146.5 "	2.22 "	1.83 "	2.02	8.7×10^{-10}
1	5.16 "	146.5 "	2.02 "	1.46 "	1.72	9.1×10^{-10}
Mean value.....						9.4×10^{-10}

Column I gives a number of successive sets of observations of the values of i_1 and i_2 ; II, the mean intensity of the γ -ray radiation during the experiment in terms of a milligramme of pure radium; III, the capacity of the electrometer system in cms.; IV and V, the values of i_1 and i_2 expressed in terms of the number of divisions of the scale moved over by the electrometer needle per second; VI, the mean of i_1 and i_2 , also expressed in scale divisions per second; VII, the calculated value of E—the charge on the α -particle—in electrostatic units. The mean value of E in each complete experiment is obtained by giving a weight to each determination of E equal to number of

168 Prof. E. Rutherford and Dr. H. Geiger. [July 17,

observations of i_1 and i_2 . It will be seen that the mean value of E from experiment I is 9.2×10^{-10} , and from experiment II 9.4×10^{-10} . Taking the mean of these, the value of E becomes 9.3×10^{-10} . We thus conclude that the positive charge E carried by an α -particle from radium C is 9.3×10^{-10} E.S. units.

From other data it is known that the α -particles from all radio-active products which have been examined are identical. Consequently, we may conclude that each α -particle, whatever its source, under normal conditions carries the above charge.

Comparison of the Charge carried by an α -Particle and a Hydrogen Atom.

The charge carried by an ion in gases has been determined by a number of observers. Townsend,* from observations on the electrified gas liberated by the electrolysis of oxygen, concluded that each particle carried a charge of about 3×10^{-10} E.S. unit. Measurements of the charge carried by an ion in gases have been made by J. J. Thomson,† H. A. Wilson,‡ Millikan and Begeman,§ using the now well-known method of causing a deposition of water on each ion by a sudden expansion. The final value of e obtained by J. J. Thomson was 3.4×10^{-10} unit, by Wilson 3.1×10^{-10} , and by Millikan 4.06×10^{-10} .

From the values found by these experimenters, it will be seen that the value E of the charge carried by an α -particle (9.3×10^{-10} unit) is between $2e$ and $3e$. On the general view that the charge e carried by an hydrogen atom is the fundamental unit of electricity, we conclude that the charge carried by an α -particle is an integral multiple of e and may be either $2e$ or $3e$.

We shall now consider some evidence based on radio-active data, which indicates that the α -particle carries a charge $2e$ and that the ordinarily accepted values of e are somewhat too small.||

First Method.—We shall first of all calculate the charge E carried by an α -particle on the assumption that the heating effect of radium is a measure of the kinetic energy of the α -particles expelled from it. There is considerable

* Townsend, 'Phil. Mag.,' February, 1898 ; March, 1904.

† J. J. Thomson, 'Phil. Mag.,' March, 1903.

‡ H. A. Wilson, 'Phil. Mag.,' April, 1903.

§ Millikan and Begeman, 'Phys. Rev.,' Feb., 1908, p. 197.

|| In a recent paper, Regener ('Verh. d. D. Phys. Ges.,' vol. 10, p. 78, 1908) has deduced from indirect data that an α -particle carries a charge $2e$. The number of scintillations from a preparation of polonium were counted and assumed to be equal to the number of α -particles emitted. A comparison was then made with the number of α -particles deduced from measurements of the ionisation current, and from the data given by Rutherford of the number of ions produced by an α -particle.

indirect evidence in support of this assumption, for it is known that the heating effect of the β - and γ -rays together is not more than a few per cent. of that due to the α -rays. If m be the mass of an α -particle and u its initial velocity of projection, the kinetic energy of the α -particle

$$= \frac{1}{2}mu^2 = \frac{1}{2} \frac{mu^2}{E} \cdot E.$$

Now, in a previous paper,* one of us has accurately determined, from the electrostatic deflection of the α -rays, the values of $\frac{1}{2} \frac{mu^2}{E}$. E for each of the four sets of α -particles expelled from radium in equilibrium, and has shown that the kinetic energy of the α -particles from 1 gramme of radium in equilibrium is $4.15 \times 10^4 NE$ ergs,† where N is the number of radium atoms breaking up per second.

Now the heating effect of the standard preparation of radium was 110 gramme-calories per gramme per hour. This is mechanically equivalent to 1.28×10^6 ergs per second. Equating the kinetic energy of the α -particles to the observed heating effect,

$$4.15 \times 10^4 NE = 1.28 \times 10^6.$$

Substituting the known value $N = 3.4 \times 10^{10}$,

$$E = 9.1 \times 10^{-10} \text{ E.S. unit.}$$

The agreement of the calculated with the observed value is somewhat closer than one would expect, taking into consideration the uncertainty of the data within narrow limits.

Second Method.—We shall now calculate the charge e carried by a hydrogen atom from the known period of transformation of radium. As a result of a series of experiments, Boltwood‡ has shown that the period of transformation of radium can be very simply measured. He concludes that radium is half transformed in 2000 years. Let P be the number of hydrogen atoms present in 1 gramme of hydrogen. Then the number of atoms of radium present in 1 gramme of radium is $P/226$, since, according to the latest determinations, the atomic weight of radium is about 226. If λ is the transformation constant of radium, the number of atoms breaking up per second per gramme of radium is $\lambda P/226$. On the probable assumption that each atom breaks up with the expulsion of one α -particle, this is equal to the number N of α -particles expelled per second per gramme. The value of N from the counting

* Rutherford, 'Phil. Mag.,' October, 1906.

† The value of E in the original paper is given in electromagnetic units. For uniformity, it is reduced here to electrostatic units.

‡ Boltwood, 'Amer. Journ. Sci.,' June, 1908.

170 Prof. E. Rutherford and Dr. H. Geiger. [July 17,

experiments is 3.4×10^{10} , consequently $\lambda P/226 = 3.4 \times 10^{10}$. From data of the electrolysis of water, it is known that

$$\begin{aligned} Pe &= 9.6 \times 10^4 \text{ electromagnetic units,} \\ &= 2.88 \times 10^{14} \text{ E.S. units,} \end{aligned}$$

where e is the charge carried by the hydrogen atom. Dividing one equation by the other, and substituting the value of $\lambda = 1.09 \times 10^{-11}$ deduced from Boltwood's measurements, we have $e = 4.1 \times 10^{-10}$ E.S. unit.

This is a novel method of determining e from radio-active data. If two α -particles instead of one are expelled during the breaking up of the radium atom, the value of e is twice the above value, or 8.2×10^{-10} . This is a value more than twice as great as that determined by other methods, and is inadmissible.

Discussion of the Accuracy of the Methods of Determination of e .

We have found, experimentally, that the α -particle carries a positive charge E of 9.3×10^{-10} unit. If the α -particle has a charge equal to $2e$, the value of e , the charge on a hydrogen atom, becomes 4.65×10^{-10} . This is a somewhat higher value than those found in the measurements of J. J. Thomson, H. A. Wilson and Millikan. It is also somewhat greater than the value deduced above from considerations based on the life of radium. As an accurate knowledge of the value of e is now of fundamental importance, we shall briefly review some considerations which indicate that the values of e found by the old methods are probably all too small. It is far from our intention to criticise in any way the accuracy of the measurements made by such careful experimenters, but we merely wish to draw attention to a source of error which was always present in their experiments, and which is exceedingly difficult to eliminate. In the experiments referred to, the number of ions present in the gas are deduced by observing the rate of fall of the ions when water has been condensed upon them by an adiabatic expansion. It is assumed that there is no sensible evaporation of the drops during the time of observation of the rate of fall. There is no doubt, however, that evaporation does occur, and that the diameter of the drops steadily decreases. A little consideration of the methods of calculation used in the experiment shows that the existence of this effect gives too large a value for the number of ions present, and, consequently, too small a value of e . The correction to be applied for this effect is no doubt a variable, depending upon the dimensions of the expansion vessel and other considerations. If the error due to this effect were about 30 per cent. in the experiments of J. J. Thomson and H. A. Wilson, and 15 per cent. in the experiments of Millikan, the corrected

value of e would agree with the value 4.65×10^{-10} deduced from measurements of the charge carried by an α -particle.

The determination of $e = 4.1 \times 10^{-10}$ from the period of transformation of radium is for other reasons probably also too small. The method adopted by Boltwood is very simple, and involves only the comparison of two quantities of radium by the emanation method. Suppose that we take a quantity of an old mineral containing 1 gramme of uranium and determine by the emanation method the quantity R of radium present. Since the uranium is in equilibrium with ionium—the parent of radium—and radium itself, the rate of production q of radium by the disintegration of its parent ionium must be equal to the rate of disintegration λR of radium itself. Now by chemical methods the ionium is separated from the mineral and the rate of growth q of radium from it determined. Consequently, $q = \lambda R$, or $\lambda = q/R$. The ratio q/R can be determined with considerable accuracy by the emanation method and does not involve any consideration of the purity of the radium standard. As Boltwood points out, the accuracy of the method of determination is mainly dependent upon the completeness of the separation of ionium from the mineral. If all the ionium is not separated, the value of λ is too small and the period of transformation consequently too long. For example, if 10 per cent. of the ionium had remained unseparated in the experiments, the period of radium would be 1800 years instead of 2000, and the charge carried by the hydrogen atom calculated from this data would be nearly 4.6×10^{-10} instead of 4.1×10^{-10} .

Considering the data as a whole, we may conclude with some certainty that the α -particle carries a charge $2e$, and that the value of e is not very different from 4.65×10^{-10} E.S. unit.*

Atomic Data.

We have seen that the method of counting the α -particles and measuring their charge has supplied a new estimate of the charge carried by the α -particle and the charge carried by a hydrogen atom. The atomic data deduced from this are for convenience collected below :—

Charge carried by a hydrogen atom = 4.65×10^{-10} E.S. unit.

Charge carried by an α -particle = 9.3×10^{-10} E.S. unit.

Number of atoms in 1 gramme of hydrogen = 6.2×10^{23} .

Mass of the hydrogen atom = 1.61×10^{-24} gramme.

Number of molecules per cubic centimetre of any gas at standard pressure and temperature = 2.72×10^{19} .

* It is of interest to note that Planck deduced a value of $e = 4.69 \times 10^{-10}$ E.S. unit from a general optical theory of the natural temperature-radiation.

Nature of the α -Particle.

The value of E/M —the ratio of the charge on the α -particle to its mass—has been measured by observing the deflection of the α -particle in a magnetic and in an electric field, and is equal to 5.07×10^8 on the electromagnetic system.* The corresponding value of e/m for the hydrogen atom set free in the electrolysis of water is 9.63×10^8 . We have already seen that the evidence is strongly in favour of the view that $E = 2e$. Consequently $M = 3.84m$, *i.e.*, the atomic weight of an α -particle is 3.84. The atomic weight of the helium atom is 3.96. Taking into account probable experimental errors in the estimates of the value of E/M for the α -particle, we may conclude that *an α -particle is a helium atom*, or, to be more precise, *the α -particle, after it has lost its positive charge, is a helium atom*.

Some of the consequences of this conclusion have already been discussed some time ago in some detail by one of us.† It suffices to draw attention here to the immediate deduction from it of the atomic weight of the various products of radium. There is direct evidence in the case of radium that each of the α -ray changes is accompanied by the expulsion of one α -particle from each atom. Consequently, since the atomic weight of radium is 226, the atomic weight of the emanation is 222 and of radium A 218. Our information is at present too scanty to decide with certainty whether a mass equal or comparable with that of an α -particle is expelled in the β -ray or rayless changes.

It is of interest to note that a recent determination by Perkins‡ of the molecular weight of the emanation from a comparison of its rate of diffusion with that of mercury vapour gives a value 235. The earlier estimates of the molecular weight from diffusion data were much lower, but more weight is to be attached to the recent value since mercury, like the emanation, is monatomic, and has an atomic weight comparable with it.

Calculation of Radio-active Data.

We are now in a position to calculate the magnitude of some important radio-active quantities.

(1) *The Volume of the Emanation.*—One atom of radium, in breaking up, emits one α -particle and gives rise to one atom of emanation of atomic mass 222. Since 3.4×10^{10} α -particles are expelled per second per gramme of radium, the number of atoms of emanation produced per second is the

* Rutherford, 'Phil. Mag.,' October, 1906.

† 'Radio-activity,' 2nd Edition, pp. 479—486; 'Radio-active Transformations, Chapter VIII.

‡ Perkins, 'Amer. Journ. Sci.,' June, 1908.

same. Now we have shown that there are 2.72×10^{19} molecules in 1 c.c. of any gas at standard pressure and temperature. The volume of the emanation produced per second per gramme is consequently 1.25×10^{-9} c.c. The maximum volume is equal to the rate of production divided by the value of the radio-active constant λ , which is equal to $1/468000$. The maximum volume of the emanation from 1 gramme of radium is consequently 0.585 cubic mm.

(2) *Rate of Production of Helium.*—Since an α -particle is an atom of helium, the number of atoms of helium produced per second per gramme of radium in equilibrium is $4 \times 3.4 \times 10^{10}$. The factor 4 is introduced, since there are 4 α -ray products in radium in equilibrium, each of which emits the same number of α -particles per second. Consequently the volume of helium produced per gramme is 5.0×10^{-9} c.c. per second, which is equal to 0.43 cubic mm. per day, or 158 cubic mms. per year. An accurate experimental determination of the rate of production of helium by radium would be of great interest.

(3) *Heating Effect of Radium.*—If the main fraction of the heat emission of radium is a result of the kinetic energy of the expelled α -particles, its value can at once be calculated. The converse problem has already been discussed earlier in the paper. It will be seen from the numbers there given that the heat emission of radium should be slightly greater than 113 gramme-calories per gramme per hour.

(4) *Life of Radium.*—From the inverse problem discussed earlier, this works out to be 1760 years, supposing the charge on a hydrogen atom equals 4.65×10^{-10} .

For convenience, the calculated values of some of the more important radio-active quantities are given below :—

Charge on an α -particle = 9.3×10^{-10} E.S. unit.

Number of α -particles expelled per gramme of radium itself,
= 3.4×10^{10} .

Number of atoms of radium breaking up per second = 3.4×10^{10} .

Volume of emanation per gramme of radium = 0.585 cubic mm.

Production of helium per gramme of radium per year = 158 cubic mms.

Heating effect per gramme of radium = 113 gramme-calories per hour.

Life of radium = 1760 years.

Calculations of the magnitude of a number of other radio-active quantities can be readily made from the experimental data given in this paper. For lack of space we shall not refer to them here.